

Landmark Preservation Committee Design Presentation

10 January 2019

38 West 8th Street
New York, NY, 10011
Straus Group





1. NORTH SIDE, LOOKING WEST FROM MACDOUGAL ST. TOWARDS SIXTH AVE.



2. NORTH SIDE, LOOKING EAST FROM MACDOUGAL ST. TOWARDS FIFTH AVE.



3. SOUTH SIDE, LOOKING WEST FROM MACDOUGAL ST. TOWARDS SIXTH AVE.



4. SOUTH SIDE, LOOKING EAST FROM MACDOUGAL ST. TOWARDS FIFTH AVE.

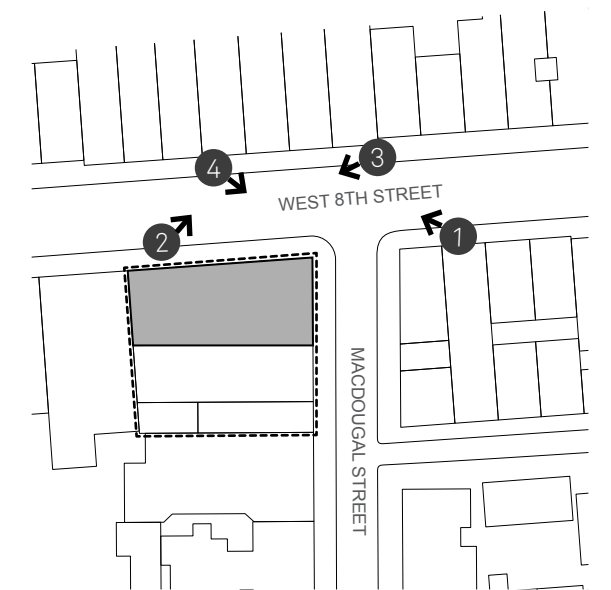



1. EAST SIDE, LOOKING SOUTH TOWARD WAVERLY PL.



2. WEST SIDE, LOOKING SOUTH TOWARD WAVERLY PL.



3. WEST SIDE, LOOKING NORTH TOWARD WEST 8TH ST.



4. EAST SIDE, LOOKING NORTH TOWARD WEST 8TH ST.

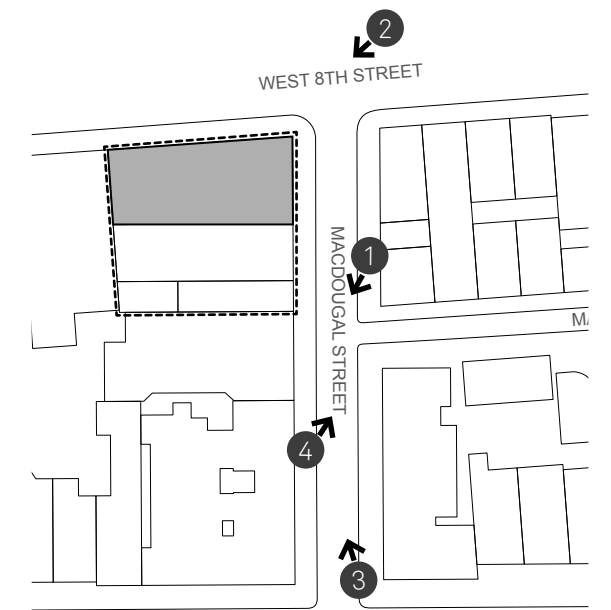



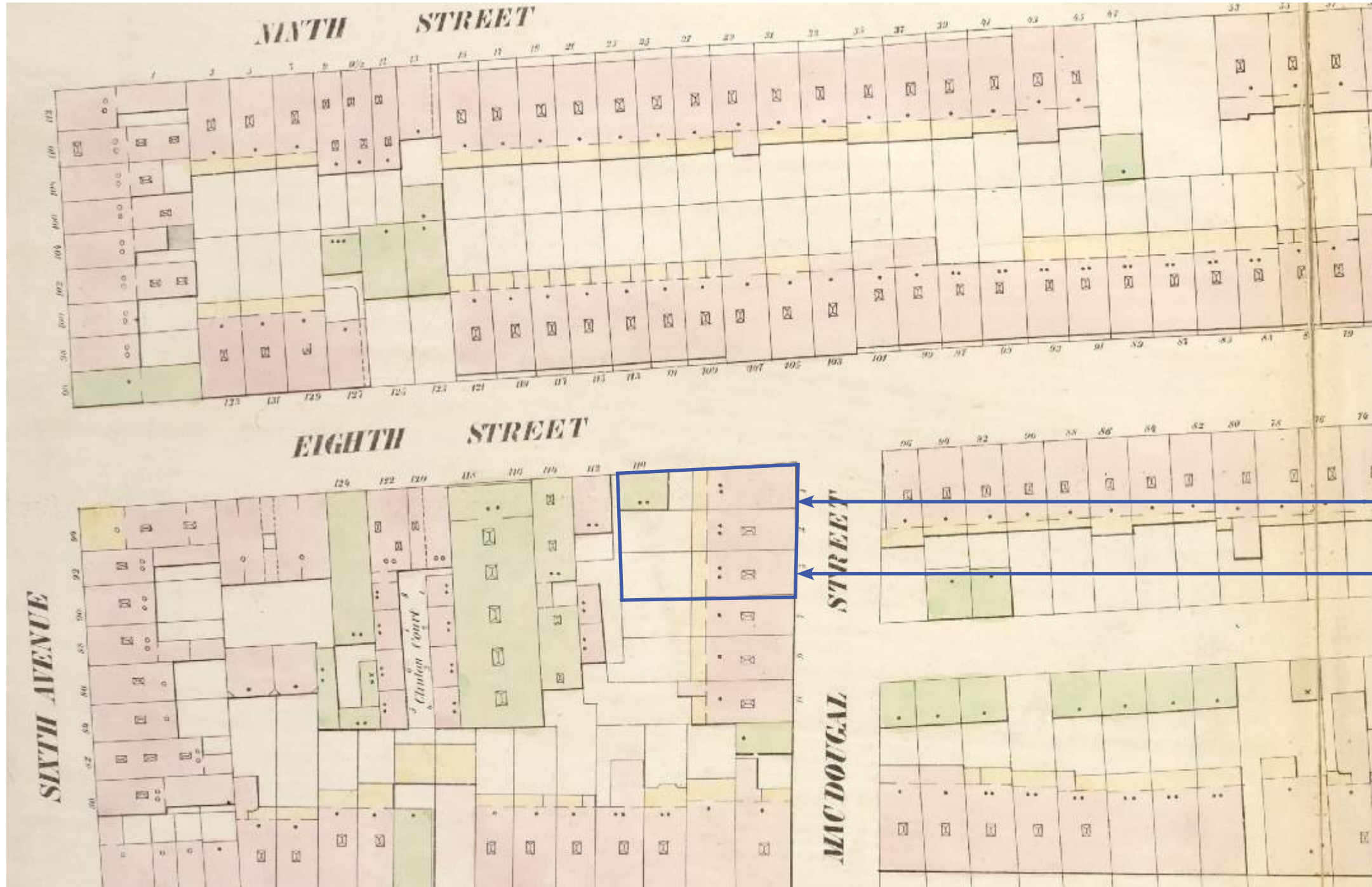

179 AND 181 MACDOUGAL: HOUSES BUILT 1846

177 MACDOUGAL: HOUSE BUILT 1834

PERRIS MAP, 1854

177 MACDOUGAL:
RECONSTRUCTED AS A
FIVE-STORY APARTMENT
BUILDING IN 1875

179 MACDOUGAL USED AS
HOTEL BEGINNING IN 1870

181 MACDOUGAL EXPANDED TO WEST
ALONG 8TH STREET, GIVEN STOREFRONT IN
1886, CONVERTED TO
HOTEL USE BY 1905

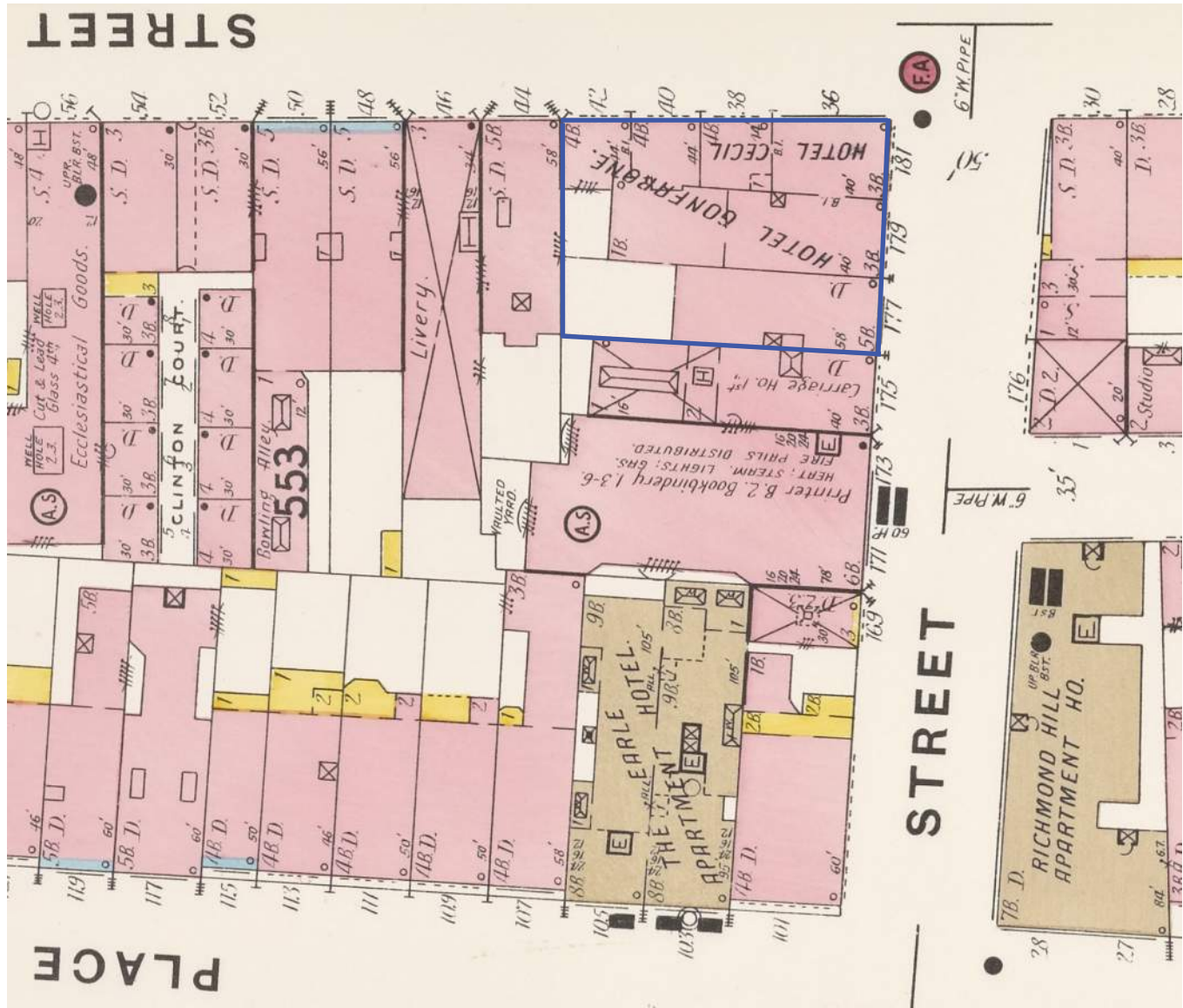

SANBORN MAP, 1904



1914 (NEW-YORK HISTORICAL SOCIETY)



1914 (NEW-YORK HISTORICAL SOCIETY)



1937 (NEW-YORK HISTORICAL SOCIETY)



EXISTING CONDITIONS



THIRD-FLOOR ALUMINUM WINDOWS



HISTORIC METAL CORNICE AND DETERIORATED WOOD WINDOWS



STREET ELEVATION



NON-HISTORIC BASEMENT ENTRY



BUILDING ENTRY - FLOOR 2-5



BUILDING ENTRY - FLOOR 2-5



NON-HISTORIC CAST-IRON LATTICE

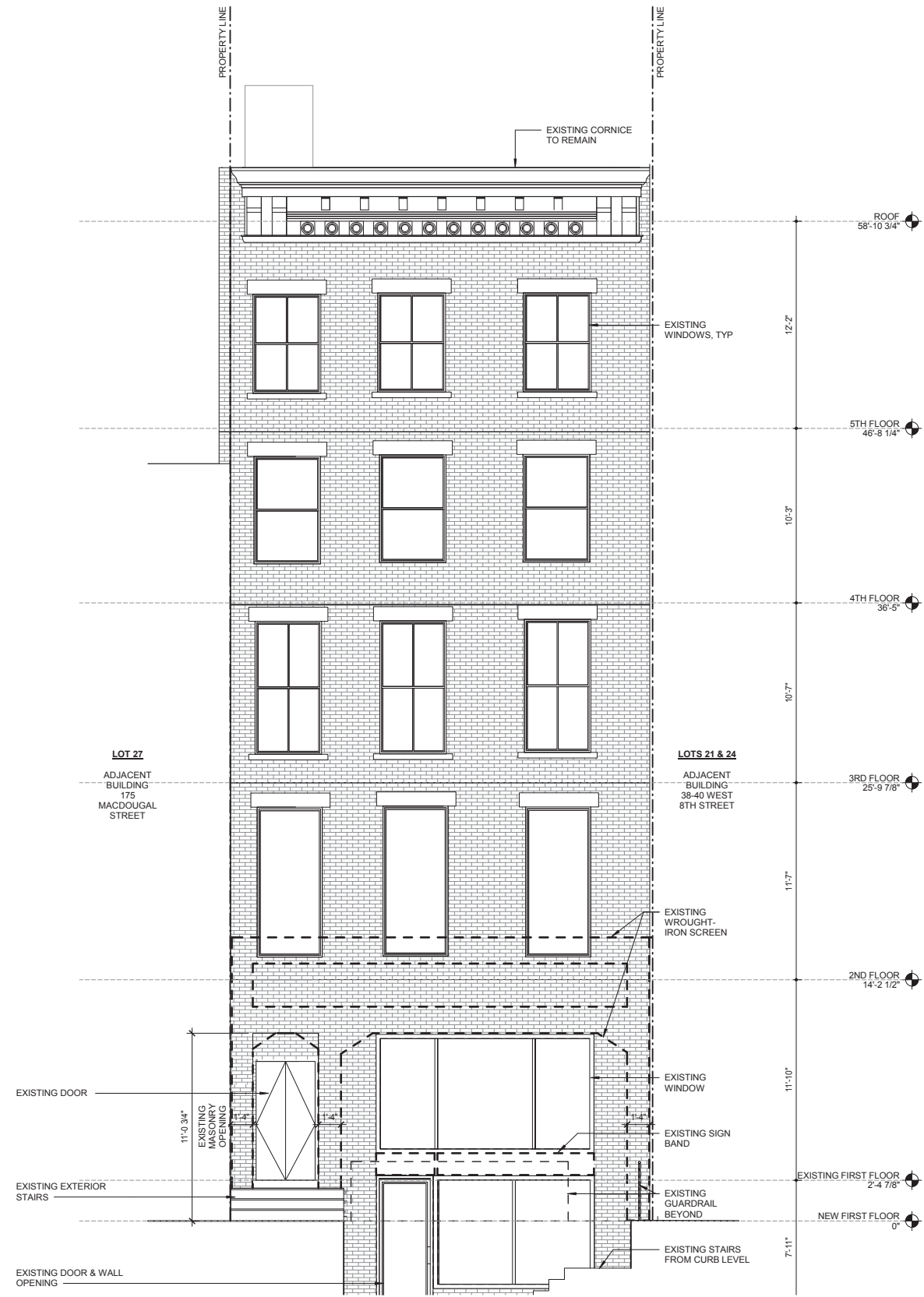

EAST ELEVATION - EXISTING

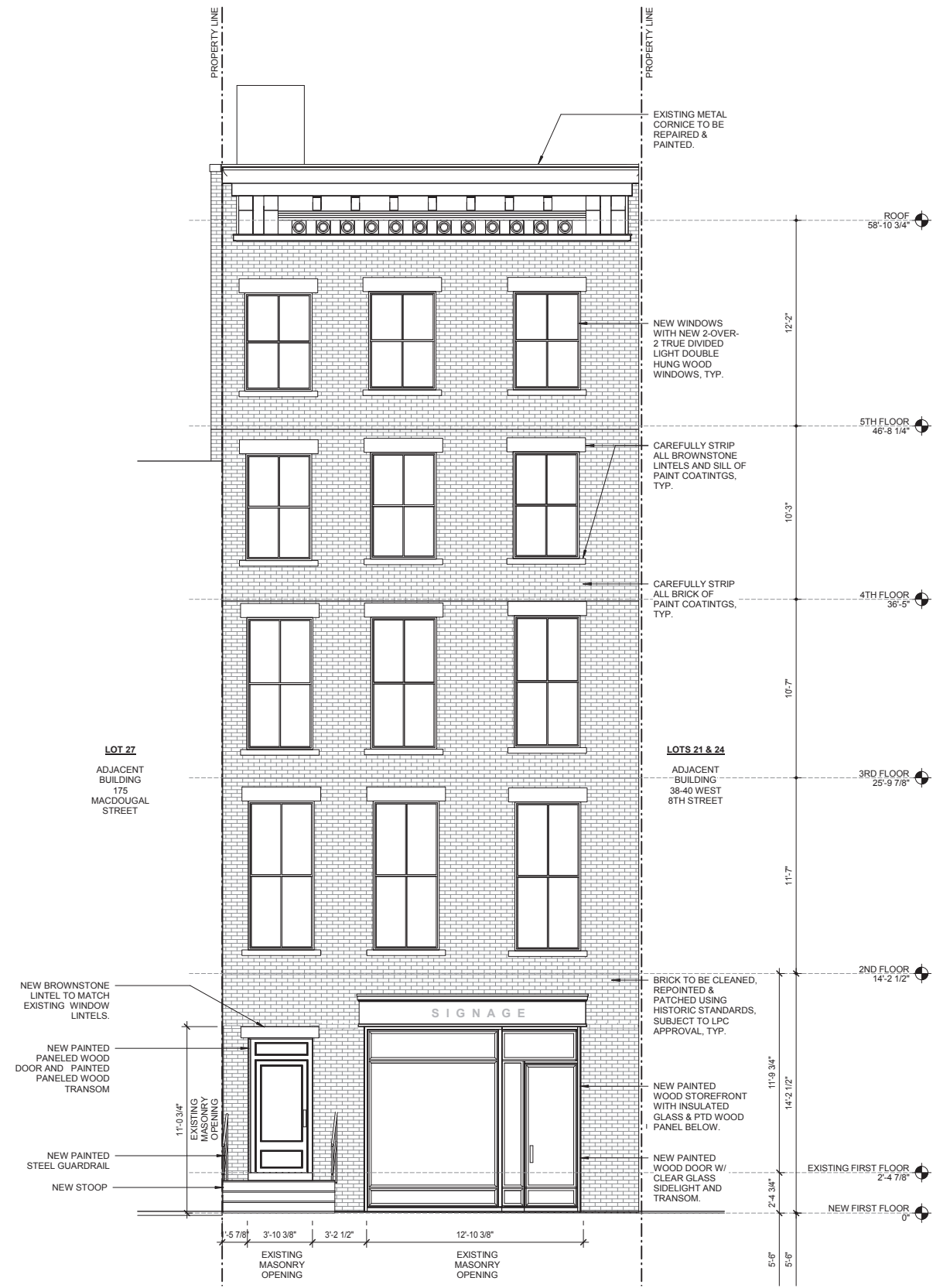

EAST ELEVATION - FACADE IMPROVEMENTS

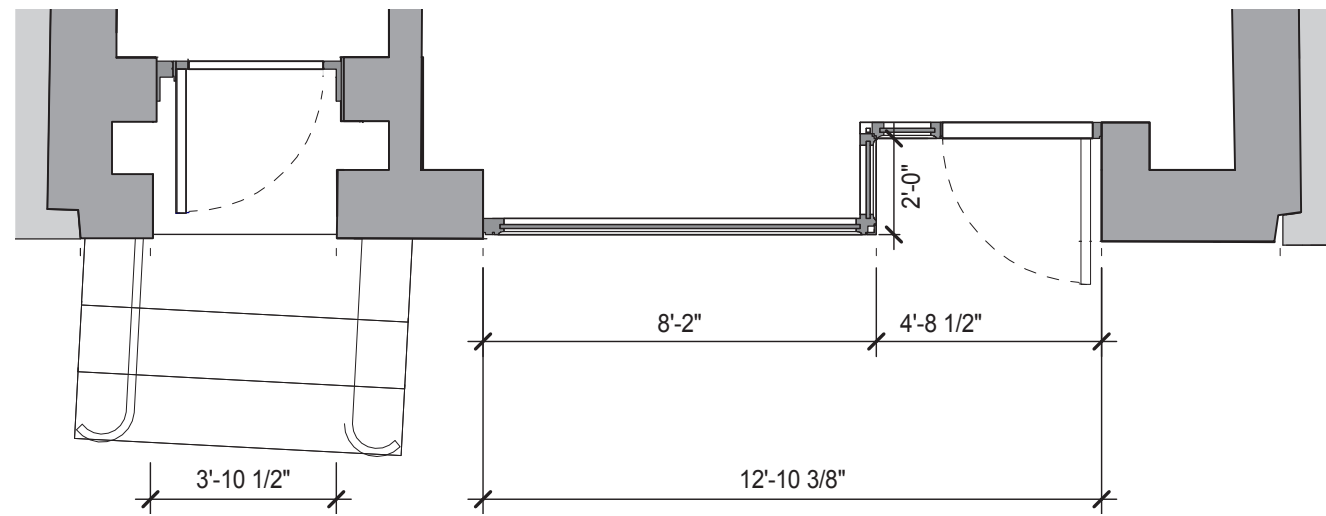
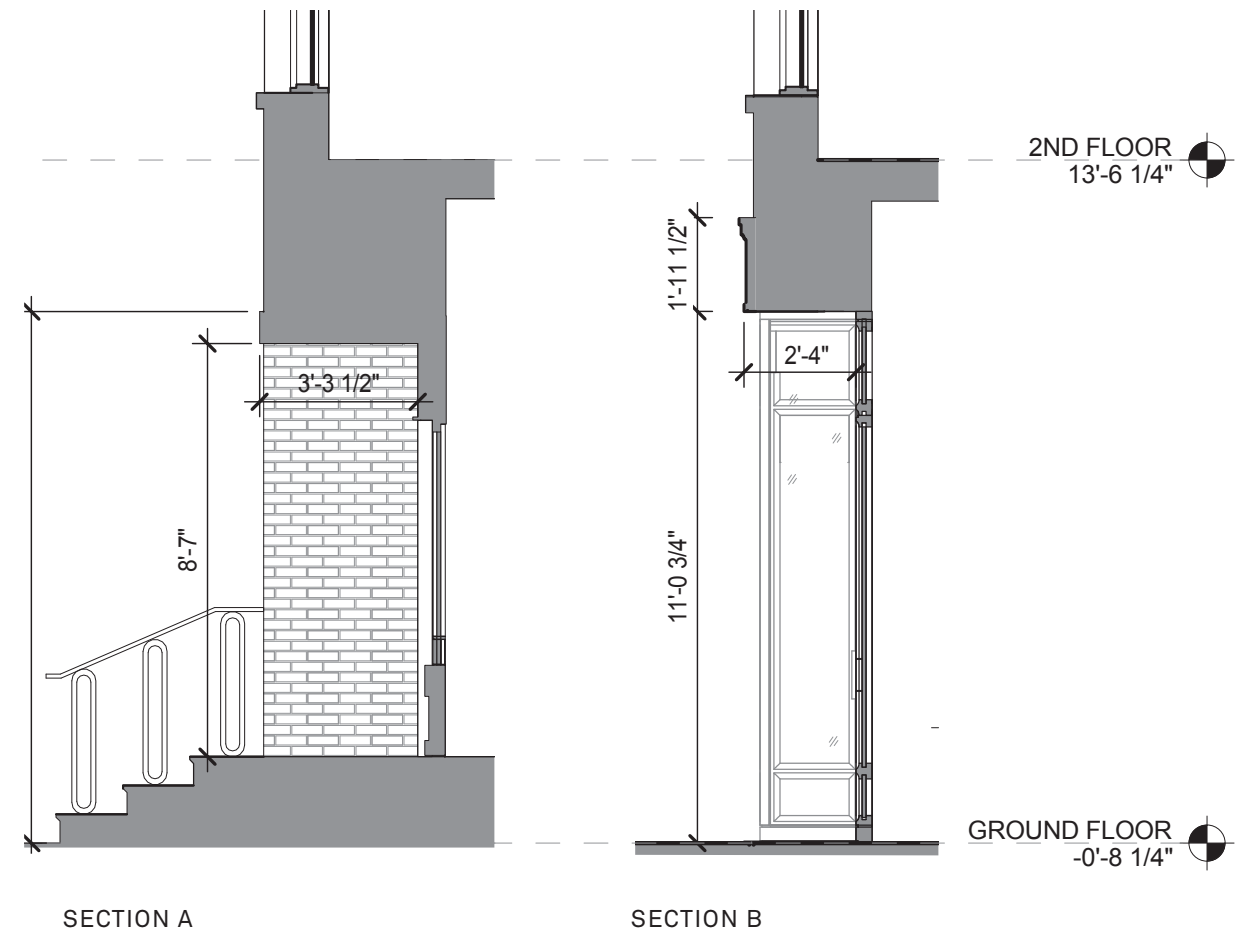



27-29 WEST 8TH STREET



30 WEST 8TH STREET



47 WEST 8TH STREET



47 WEST 8TH STREET

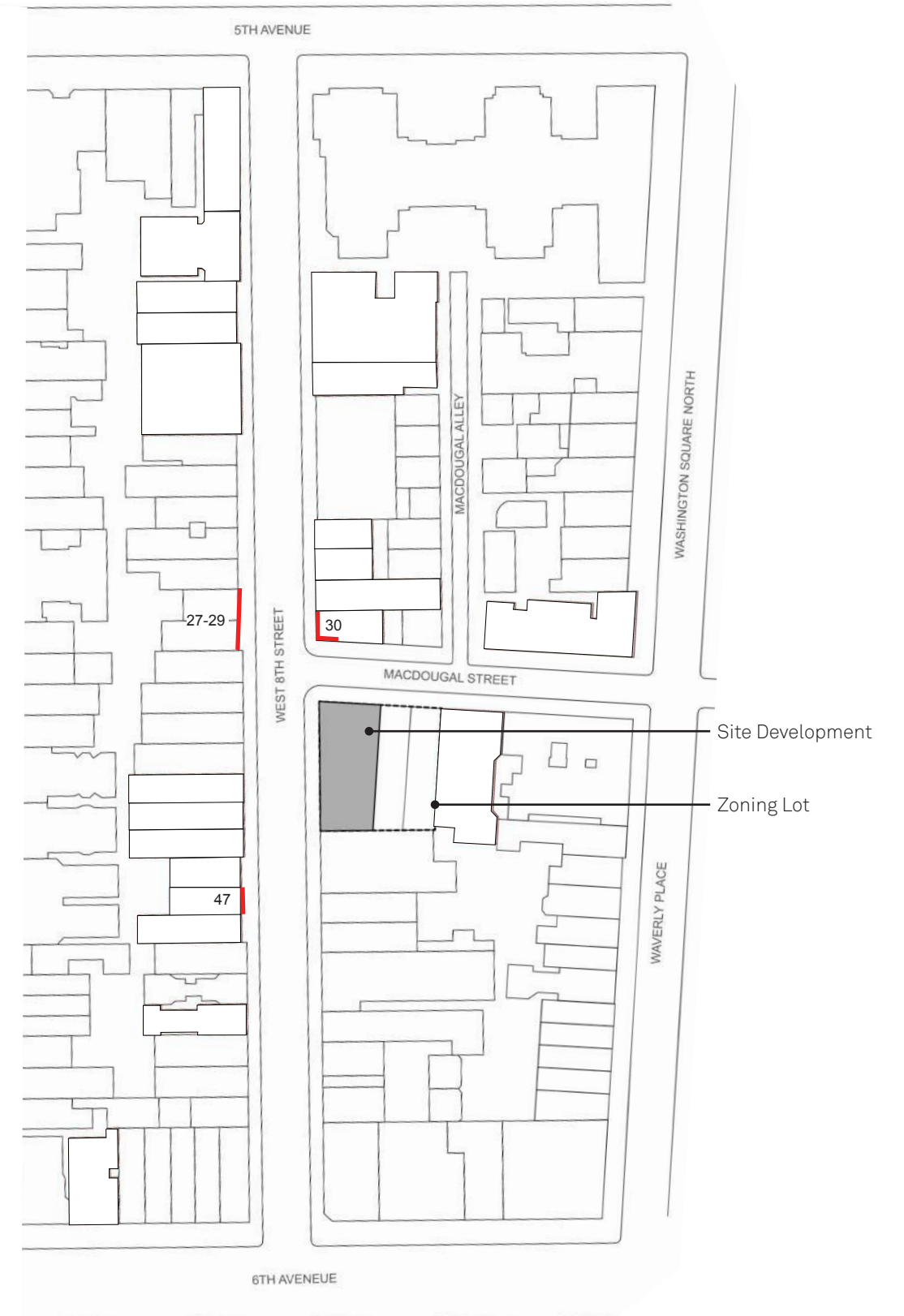

KEY MAP



1937 (NEW-YORK HISTORICAL SOCIETY)



C. 1940 NEW YORK CITY TAX PHOTO



C. 1940 NEW YORK CITY TAX PHOTO



179 MACDOUGAL STREET



40-42 WEST 8TH STREET



181 MACDOUGAL STREET



38 WEST 8TH STREET



181 MACDOUGAL STREET



38 WEST 8TH STREET





5 WEST 8TH STREET



27 WASHINGTON SQUARE NORTH, AT MACDOUGAL ST.



11 WEST 8TH STREET

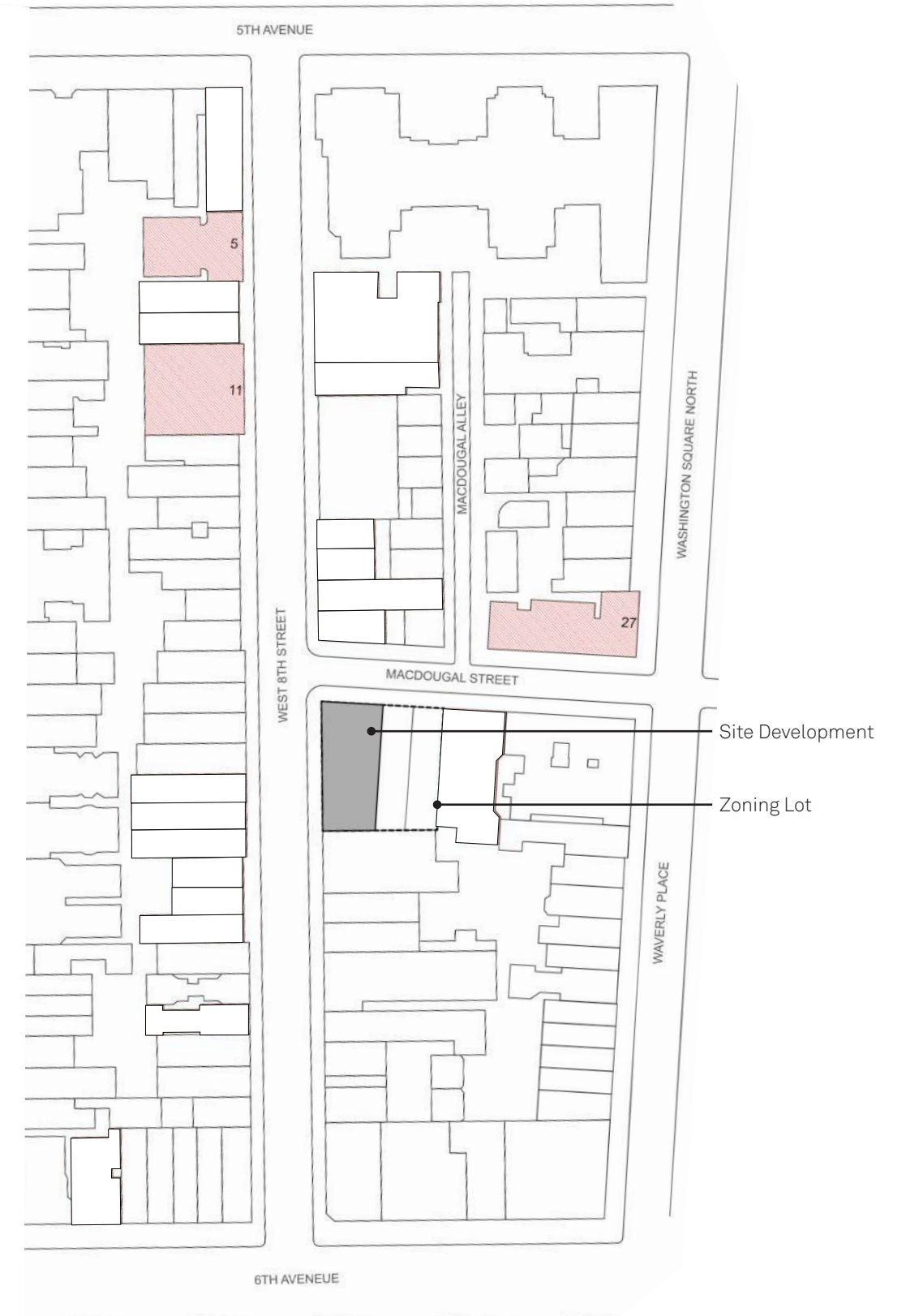

KEY MAP



5 WEST 8TH STREET



48 WEST 8TH



30 WEST 8TH STREET



30 CHARLES STREET



KEY MAP





39 WEST 8TH STREET



55 WEST 8TH STREET



171 MACDOUGAL STREET



414 SIXTH AVENUE



KEY MAP

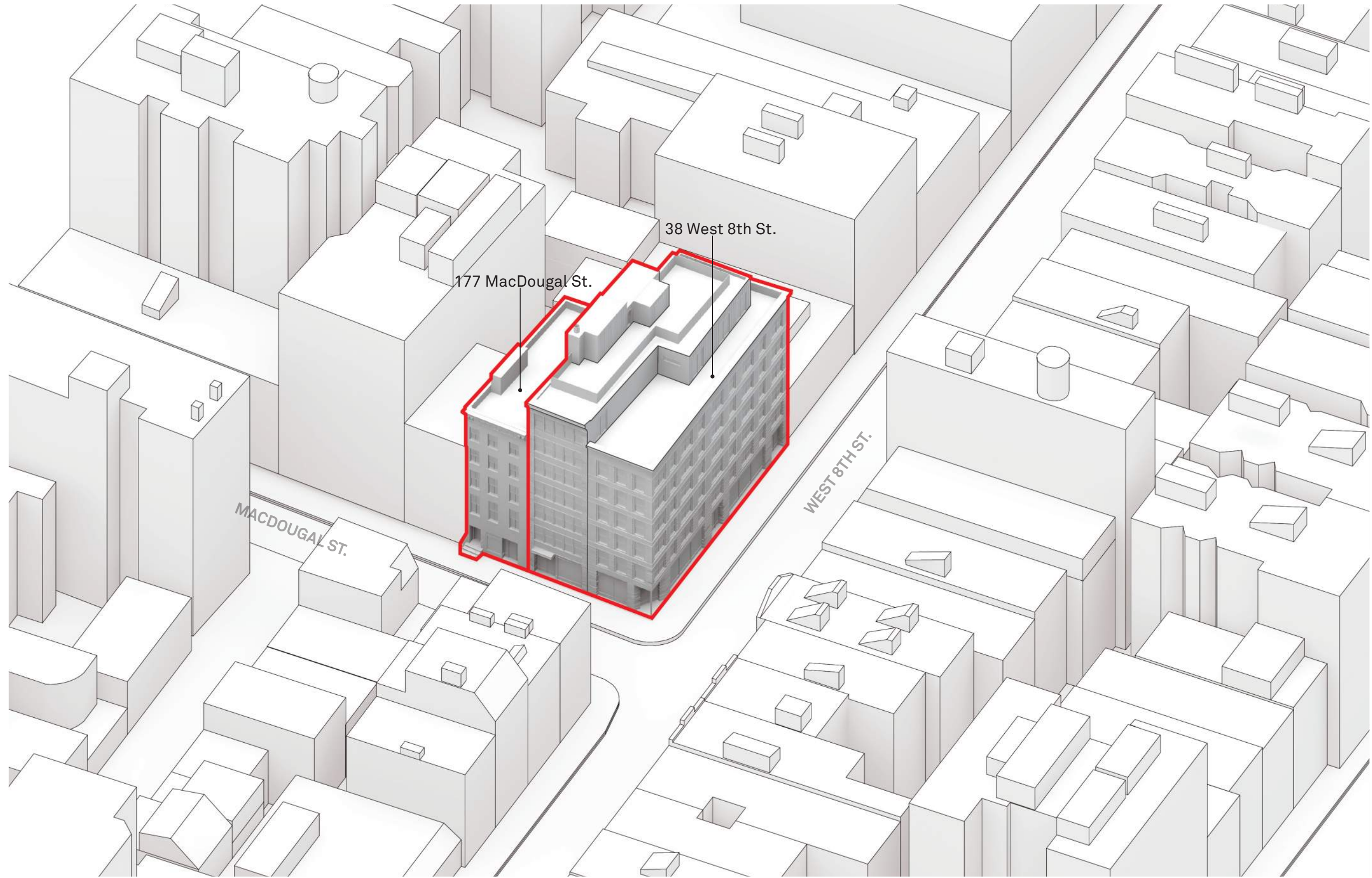

AERIAL SITE VIEW





MACDOUGAL ST.

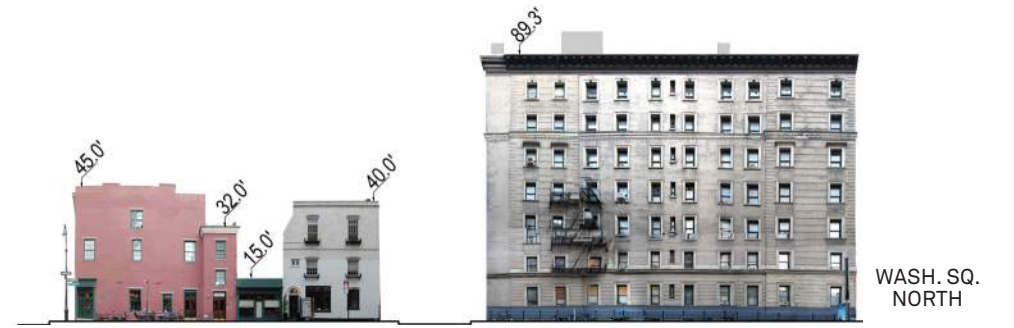



- CLEAR GLASS W/ PREFINISHED PTD. MTL. FRAME, COLOR TO MATCH STOREFRONT
- PREFINISHED PTD. MTL. WINDOW MULLION
- MODULAR BULLNOSE BRICK HEADER
- MODULAR BRICK SPANDREL, RUNNING BOND
- PREFINISHED PTD. MTL. MARQUEE BULLNOSE MODULAR BRICK HEADER
- CORBELLED MODULAR BRICK IN ENGLISH BOND
- CLEAR GLASS W/ PREFINISHED PTD. MTL. FRAME
- CLEAR GLASS SWING DOORS W/ PREFINISHED PTD. MTL. FRAME
- PREFINISHED PTD. MTL. STOREFRONT POST
- CAST STONE BASE
- PREFINISHED PTD. MTL. BASE

ENLARGED ELEVATION

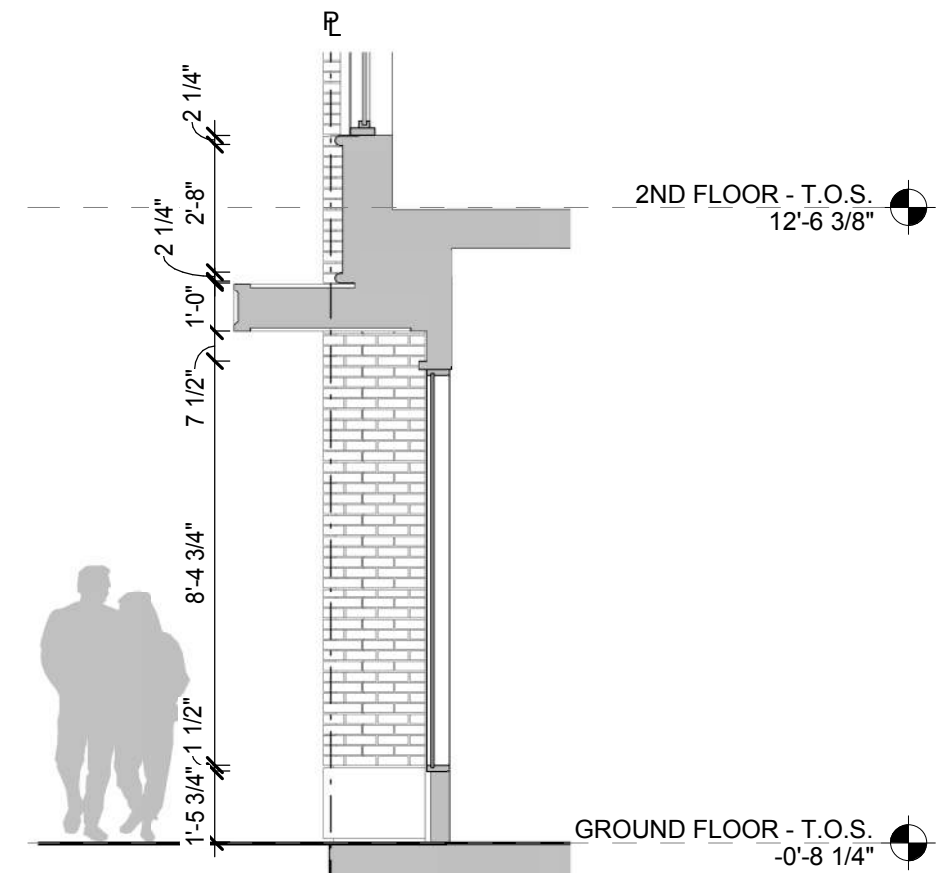

SECTION

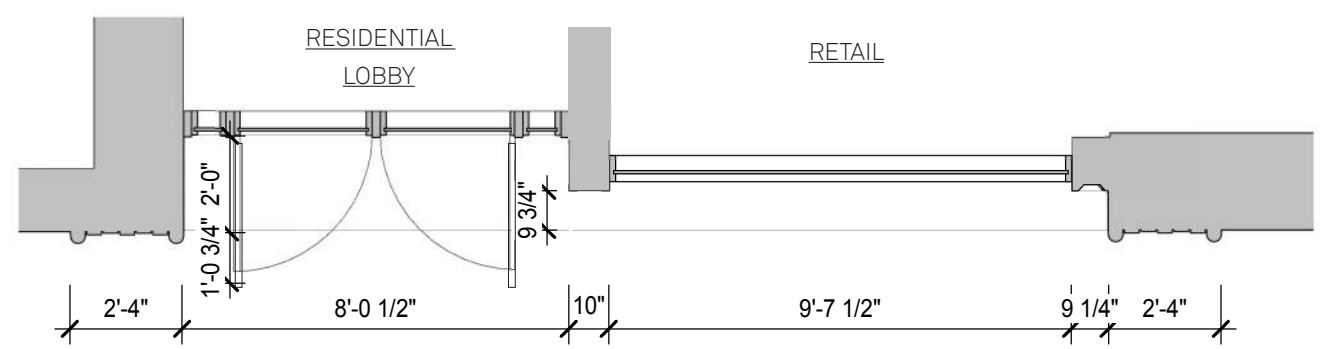

PLAN



DETAIL 1: PIER BASE & STOREFRONT COLUMN



- BULLNOSE MODULAR BRICK HEADER
- CORBELLED MODULAR BRICK IN ENGLISH BOND
- MODULAR BRICK SPANDREL, RUNNING BOND
- MODULAR BULLNOSE BRICK HEADER
- CLEAR GLASS DOUBLE HUNG WINDOW WITH PREFINISHED PTD. MT. FRAME, COLOR TO MATCH STOREFRONT
- PREFINISHED PTD. MTL. WINDOW MULLION
- MODULAR BULLNOSE BRICK SILL

ENLARGED ELEVATION

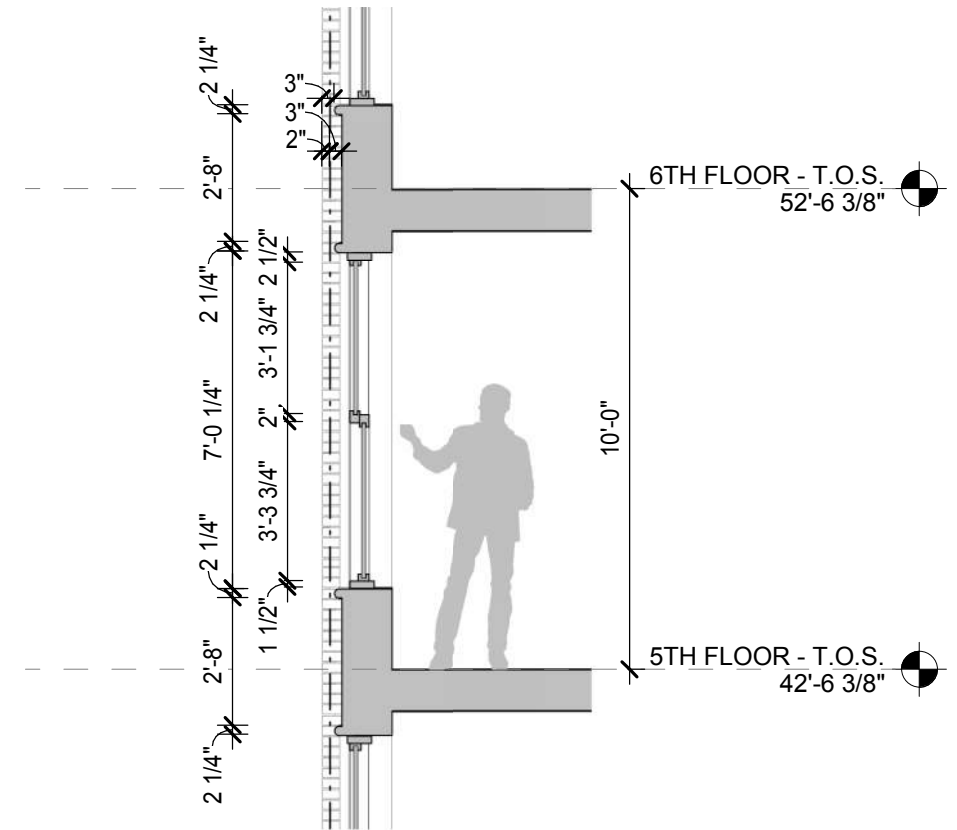

SECTION

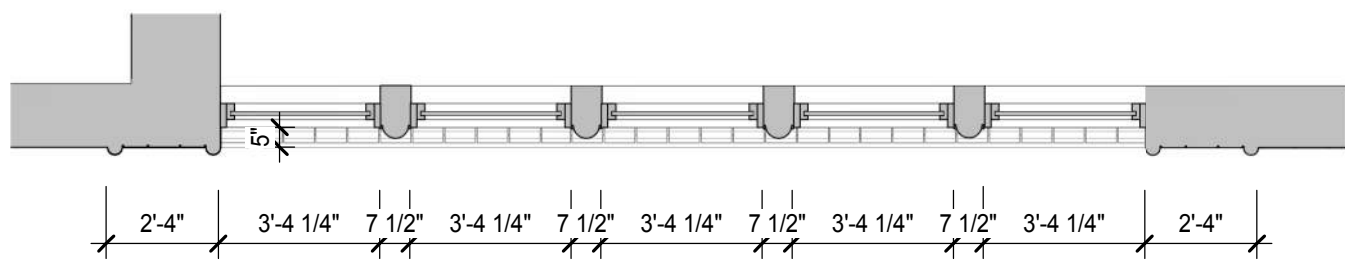

PLAN

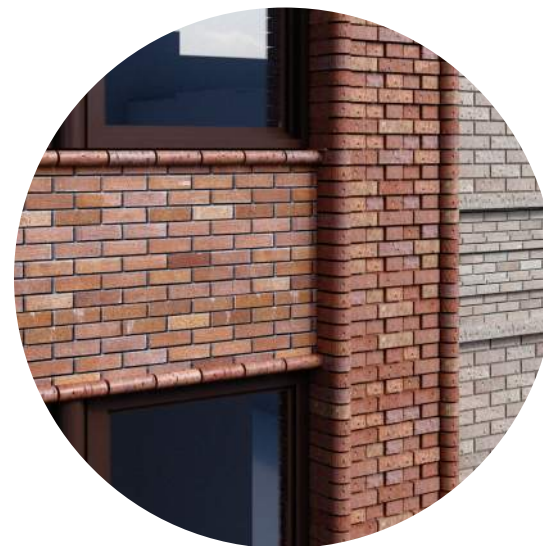

DETAIL 1: BRICK PIER



DETAIL 2: WINDOW MULLION

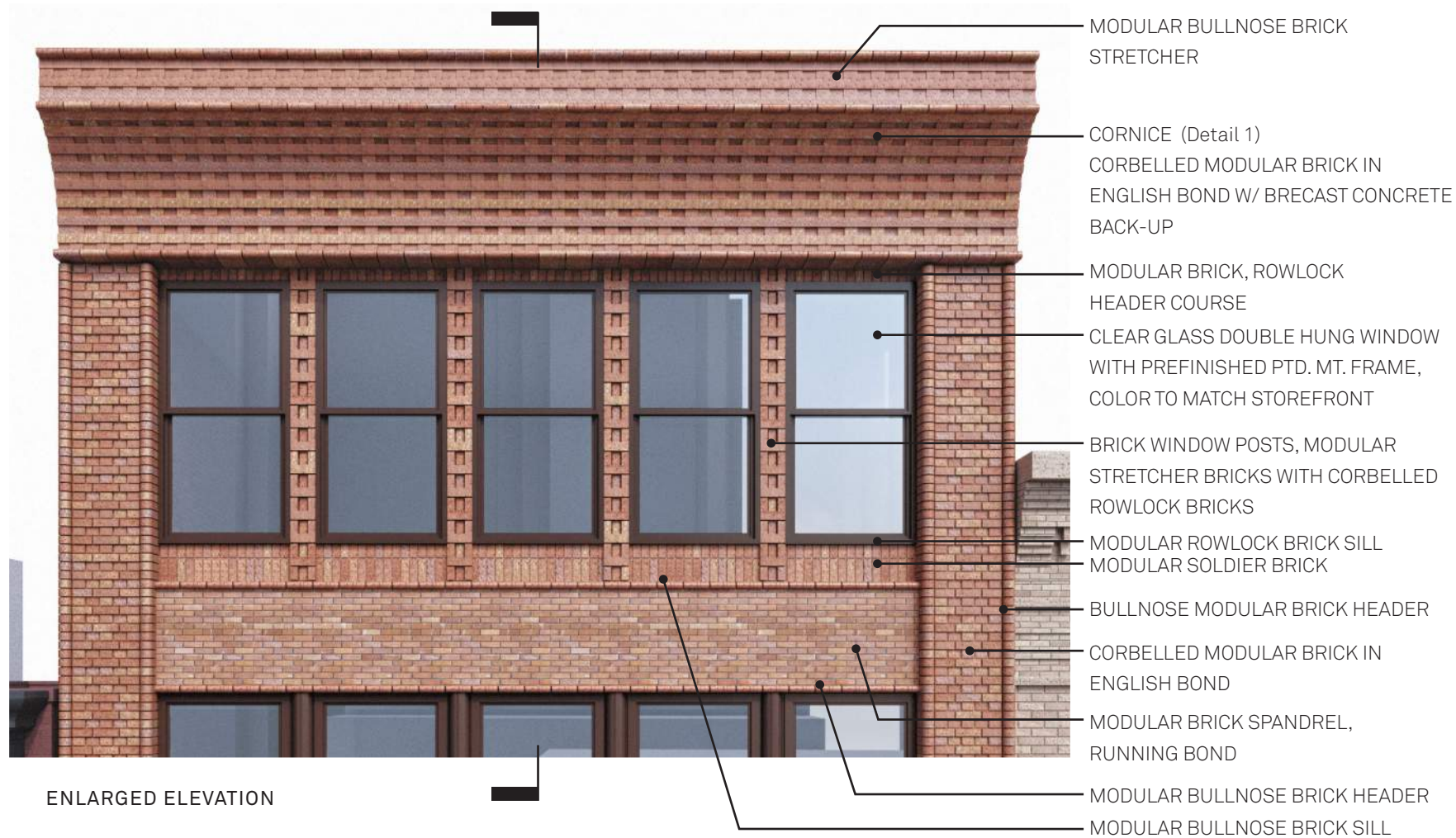

ENLARGED ELEVATION

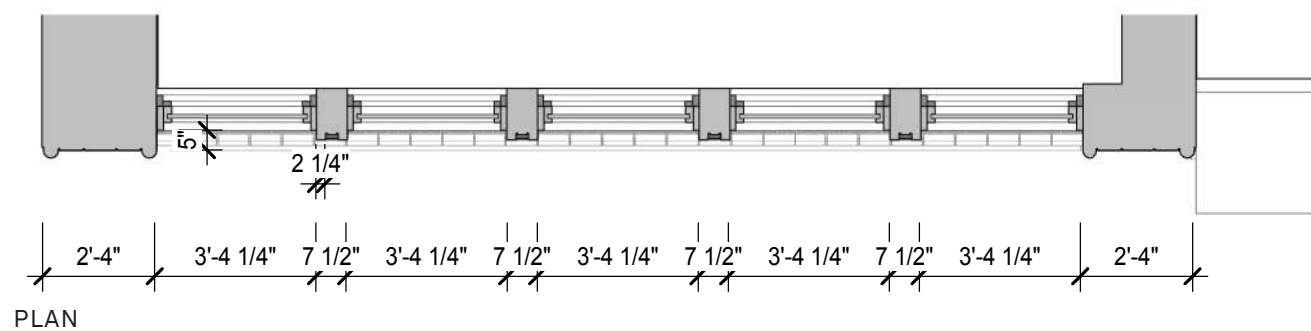
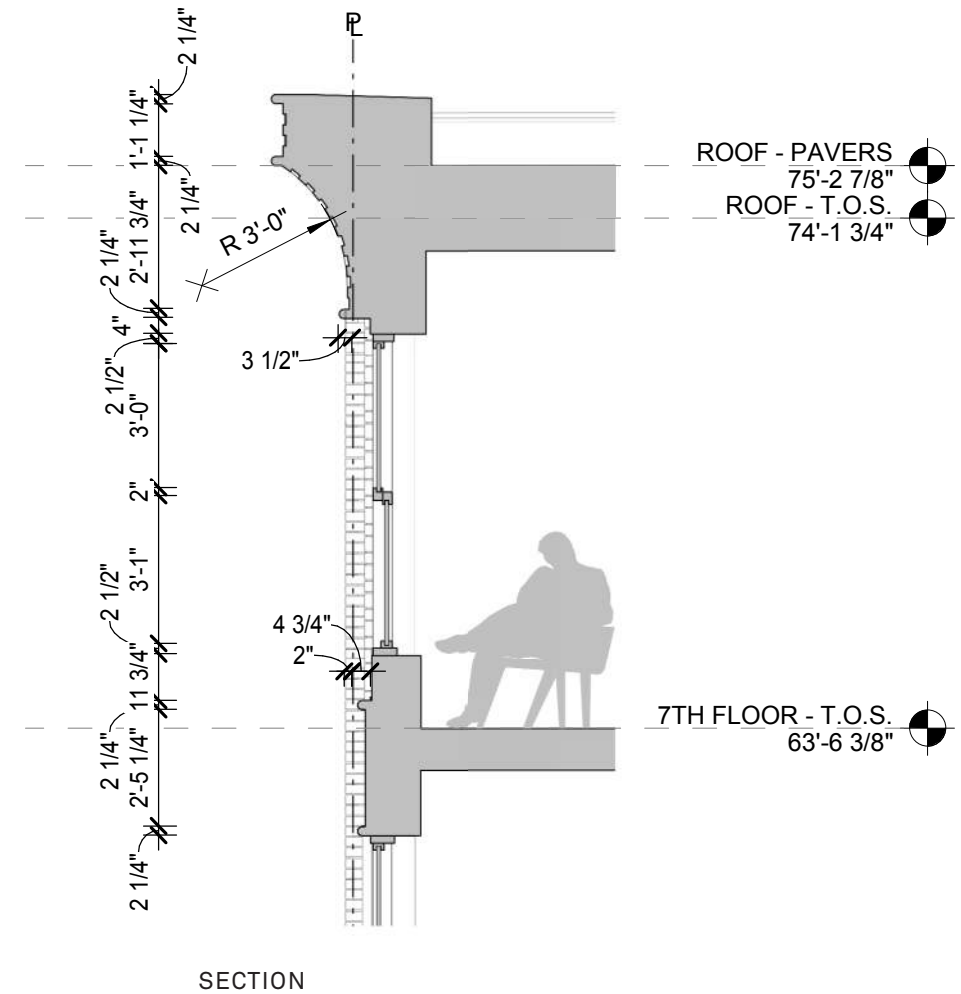

DETAIL 1: BRICK PIER



DETAIL 2: WINDOW MULLION



- CLEAR GLASS DOUBLE HUNG DIVIDED LITE WINDOW WITH PREFINISHED PTD. MTL. FRAME, COLOR TO MATCH STOREFRONT
- CAST STONE WINDOW SILL
- BRICK RUSTICATION
- PREFINISHED PAINTED METAL FLUTED COLUMN
- CLEAR GLASS SWING DOORS W/ PREFINISHED PTD. MTL. FRAME
- CLEAR GLASS WINDOWS W/ PREFINISHED PTD. MTL. FRAME
- METAL BASE

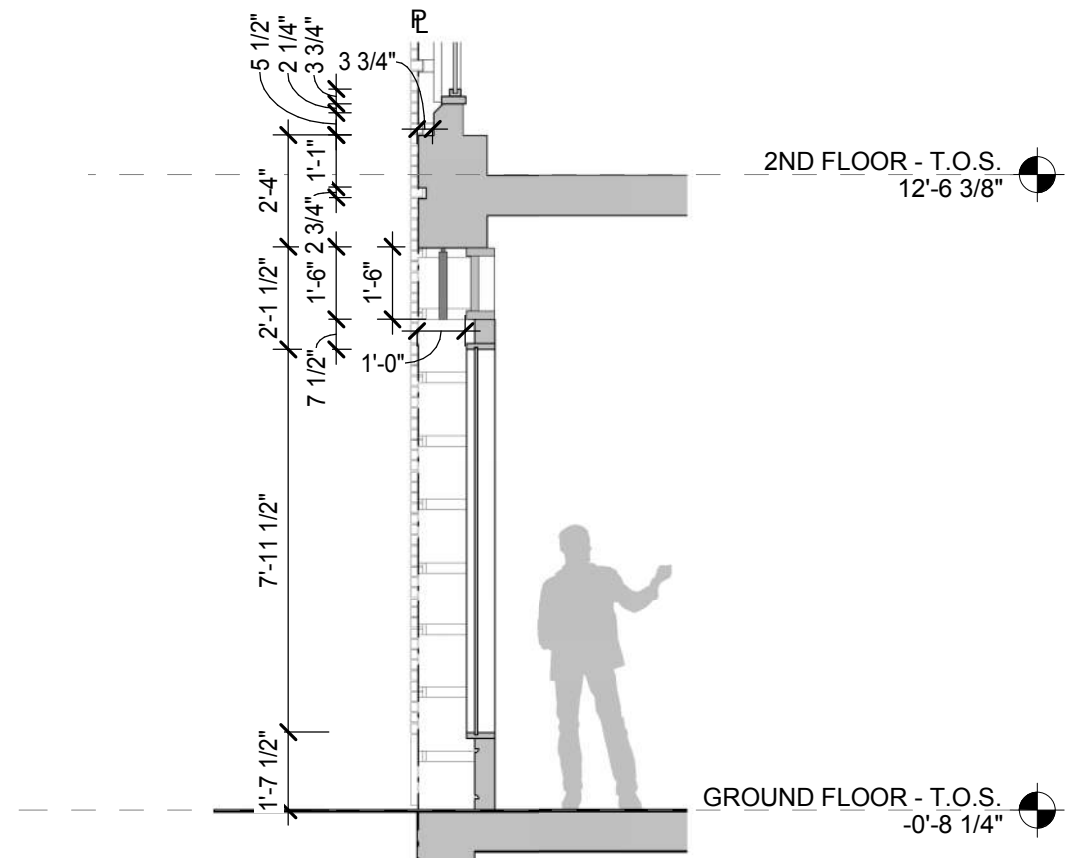

ENLARGED ELEVATION

SECTION

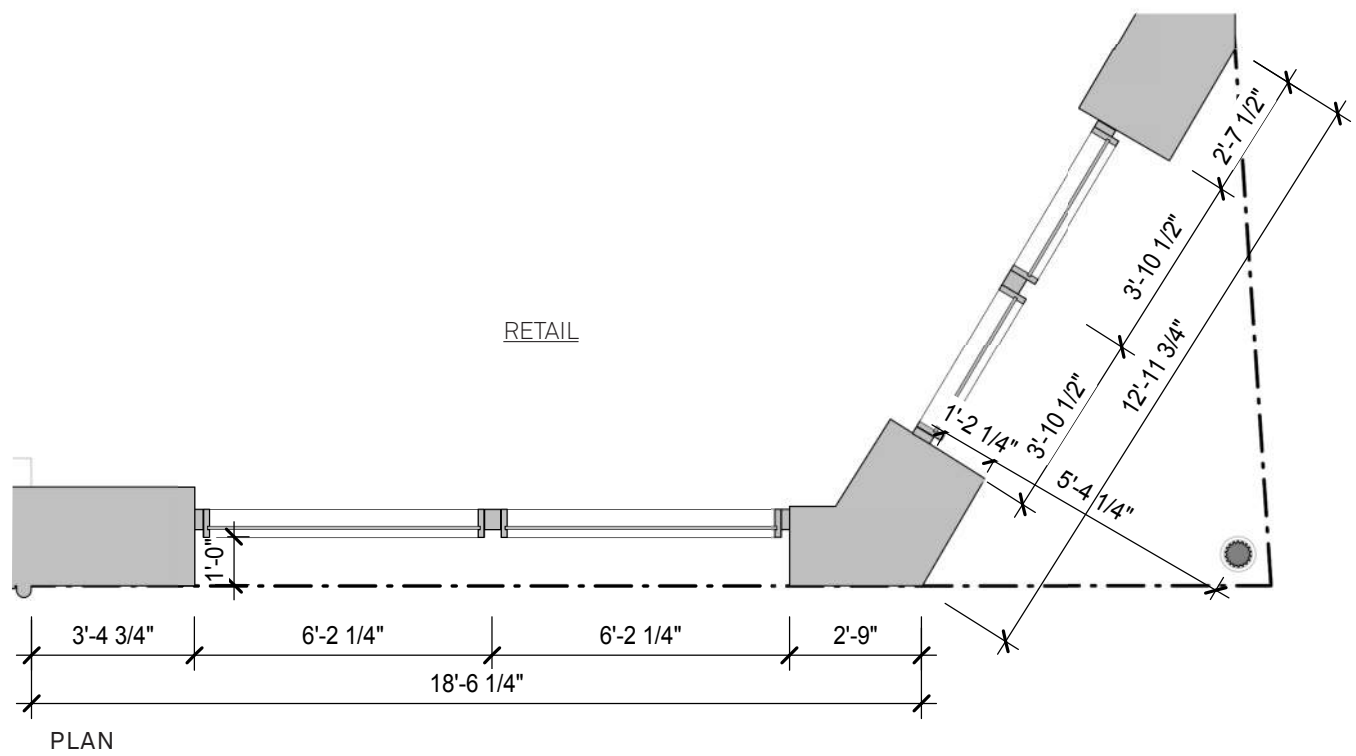

DETAIL 1: BRICK PIER



- CAST STONE BANDING
- CORBELLED RUNNING BOND
MODULAR BRICK
- CAST STONE BANDING
- SOLDIER HEADER W/
MODULAR BRICK
- BRICK PIER, RECESSED
- ALTERNATING MODULAR BRICK
- CLEAR GLASS DOUBLE HUNG
DIVIDED LITE WINDOW WITH
PREFINISHED PTD. MTL. FRAME,
COLOR TO MATCH STOREFRONT
- CAST STONE WINDOW SILL

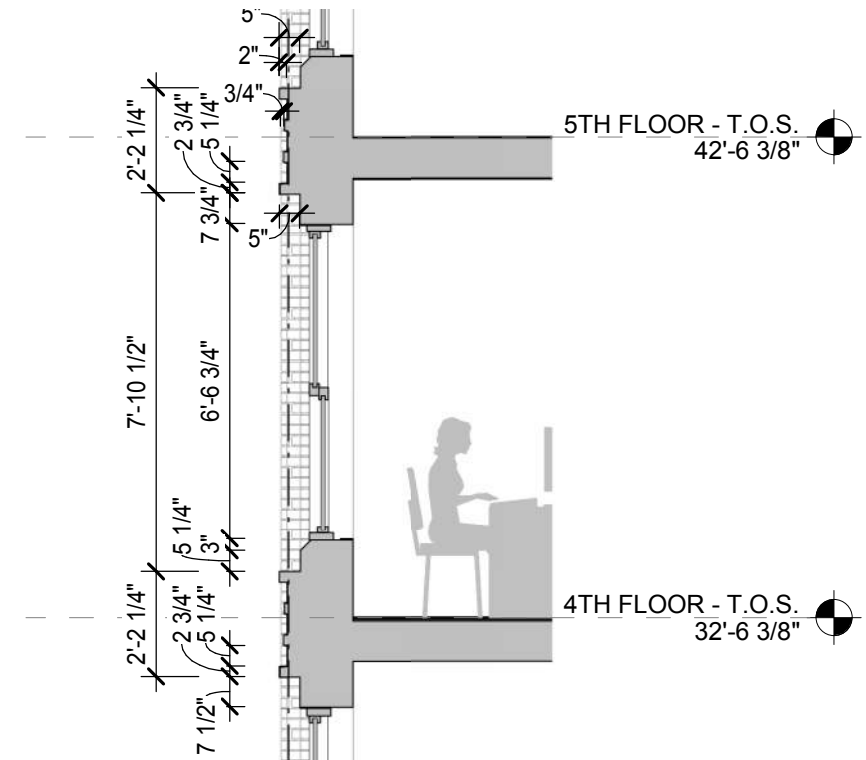

ENLARGED ELEVATION

SECTION

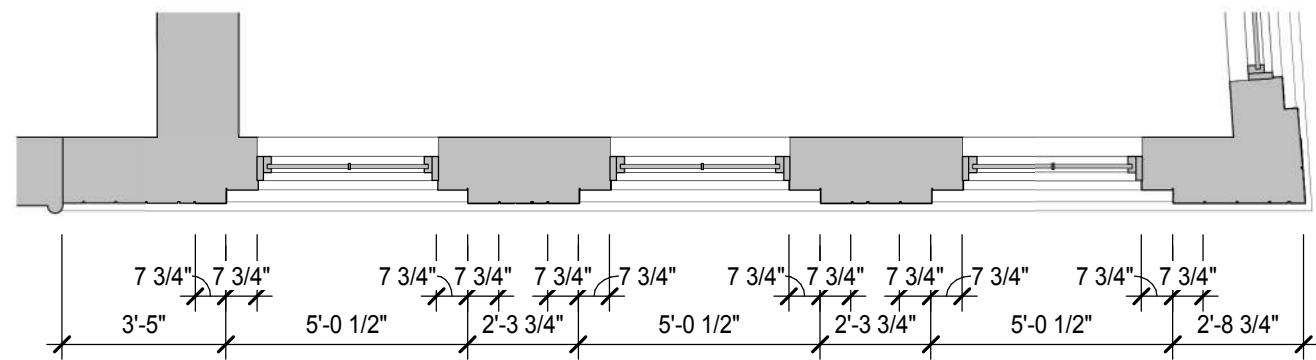

PLAN

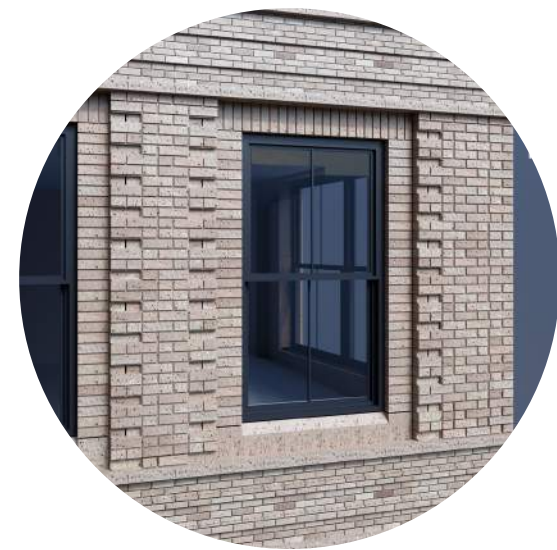

DETAIL 1: BRICK PIER &
WINDOW SURROUND

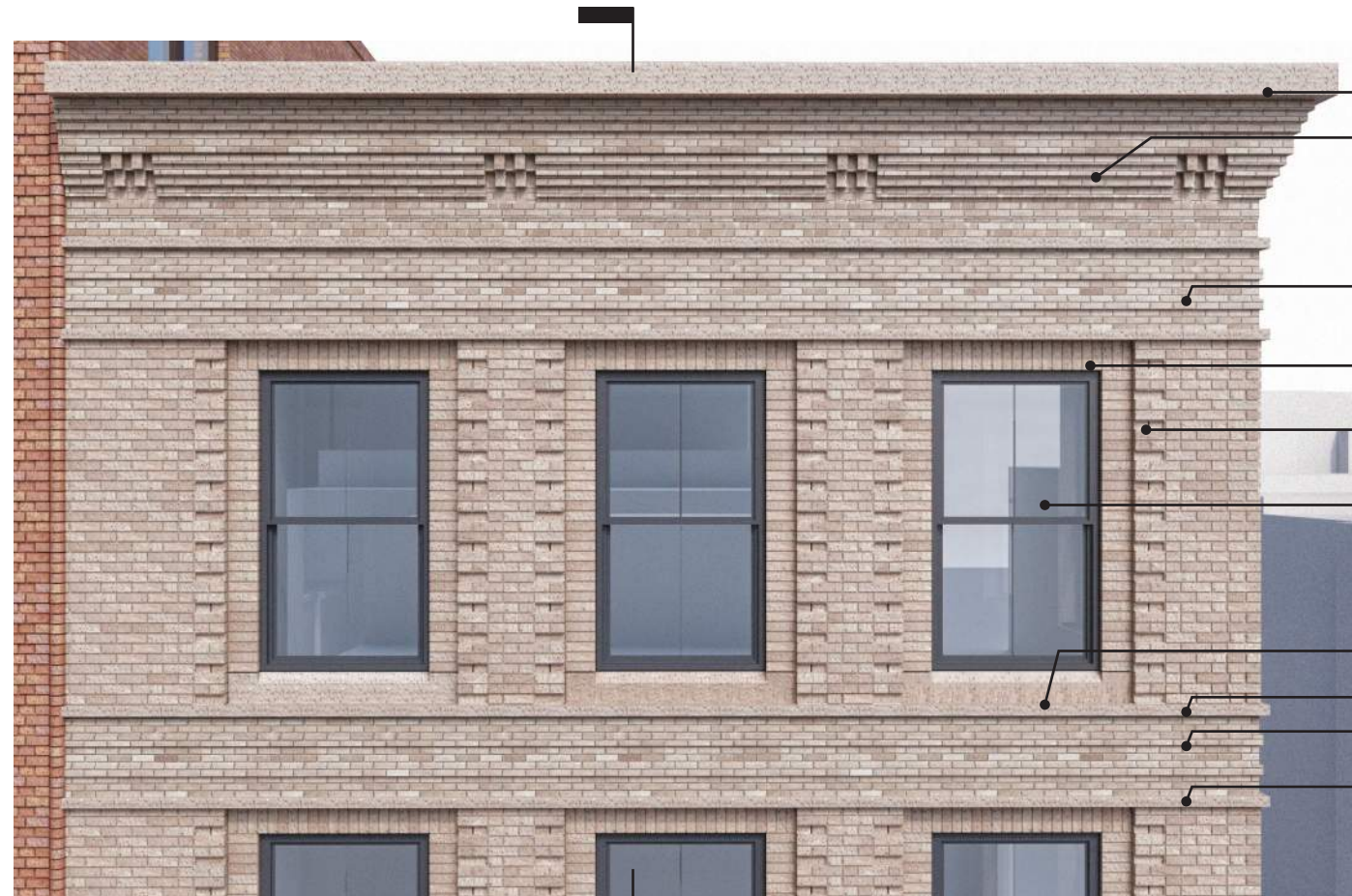

- CAST STONE CAP
- CORBELLED MODULAR BRICK CORNICE IN RUNNING BOND W/ CORBELLED ROWLOCK DENTI
- CORBELLED RUNNING BOND MODULAR BRICK
- SOLDIER HEADER W/ MODULAR BRICK
- RECESSED ALTERNATING MODULAR BRICK
- CLEAR GLASS DOUBLE-HUNG DIVIDED LITE WINDOW W/ PTD. MTL. FRAME TO MATCH STOREFRONT
- CAST STONE WINDOW SILL
- CAST STONE BANDING
- CORBELLED RUNNING BOND MODULAR BRICK
- CAST STONE BANDING

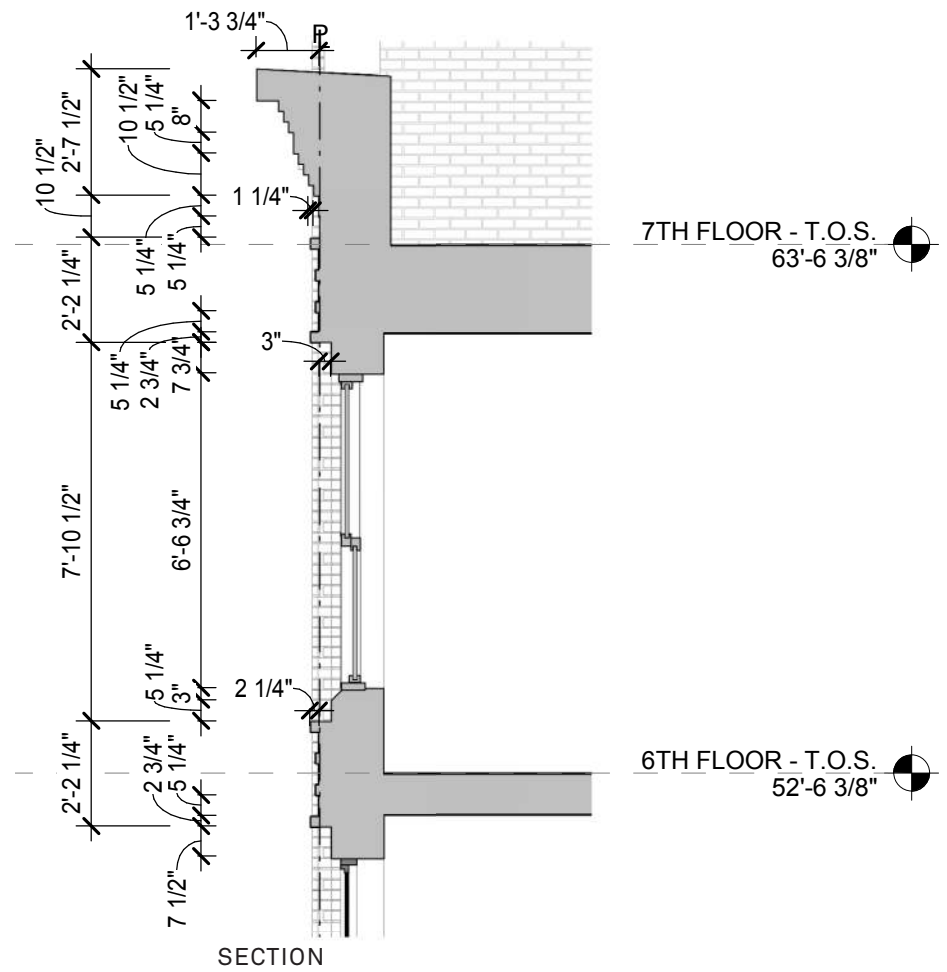

ENLARGED ELEVATION

SECTION

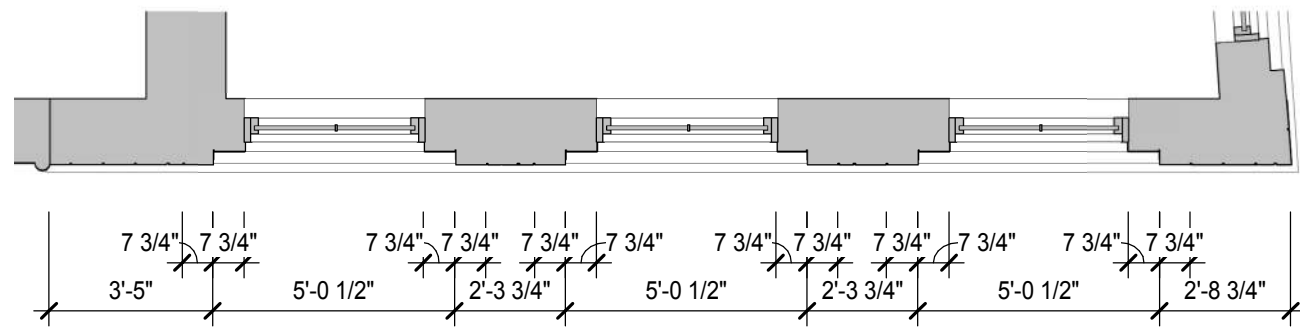

PLAN



DETAIL 1: CORNICE

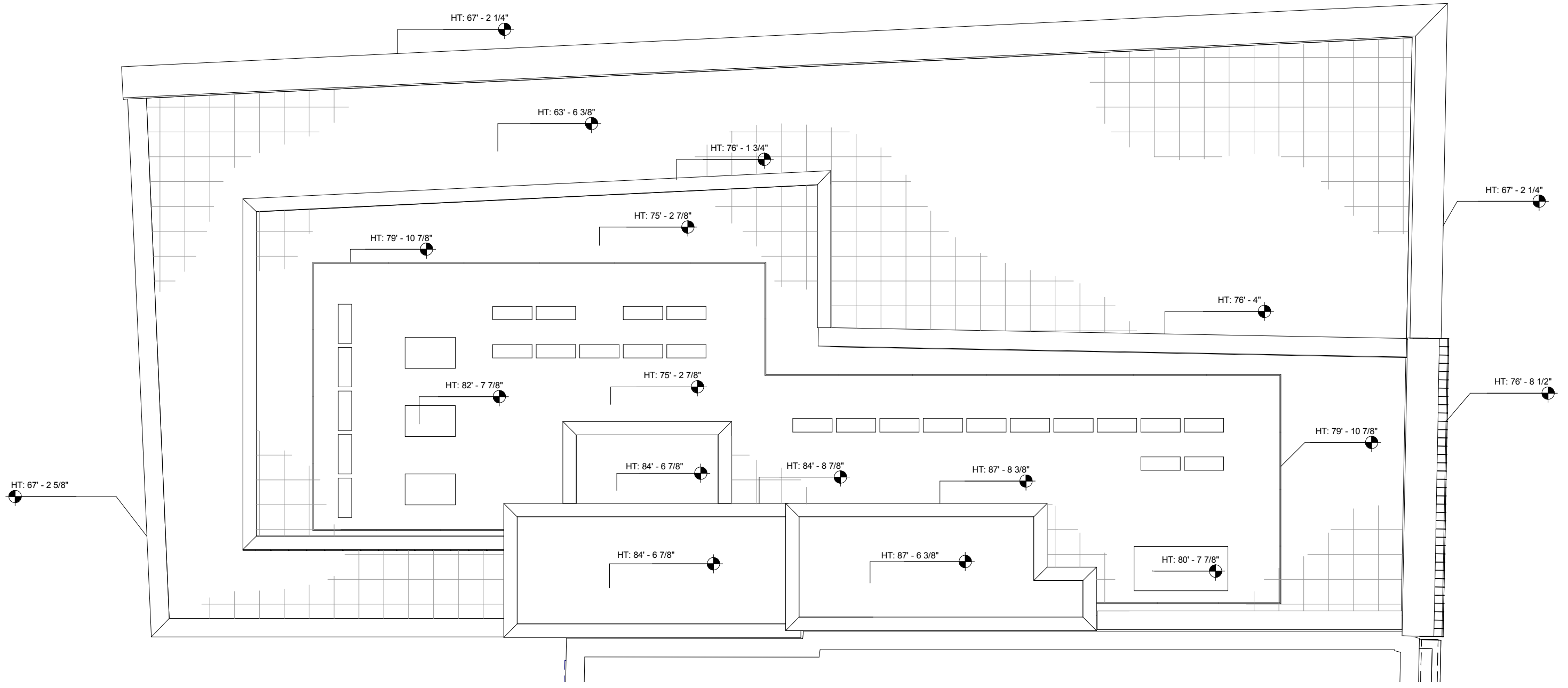
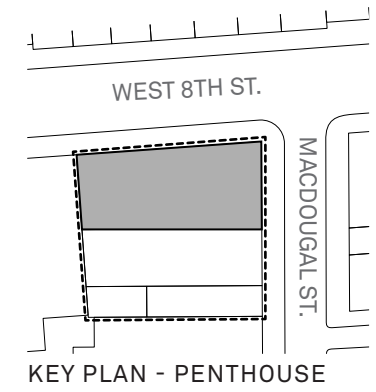

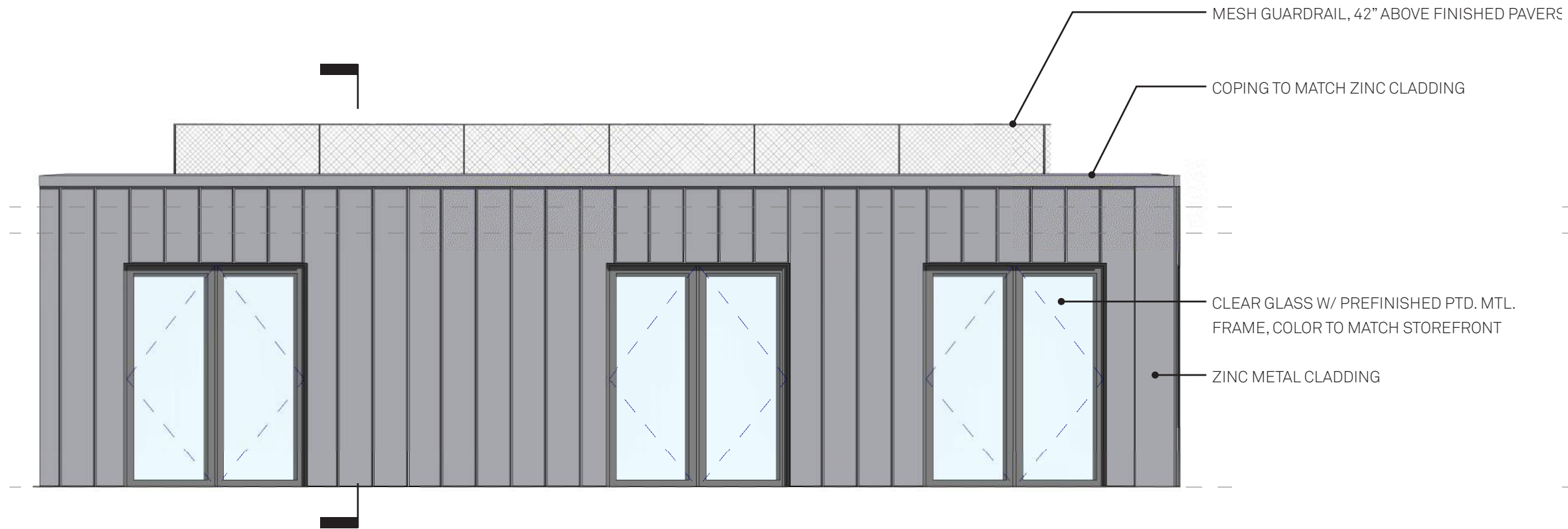

ENLARGED ELEVATION

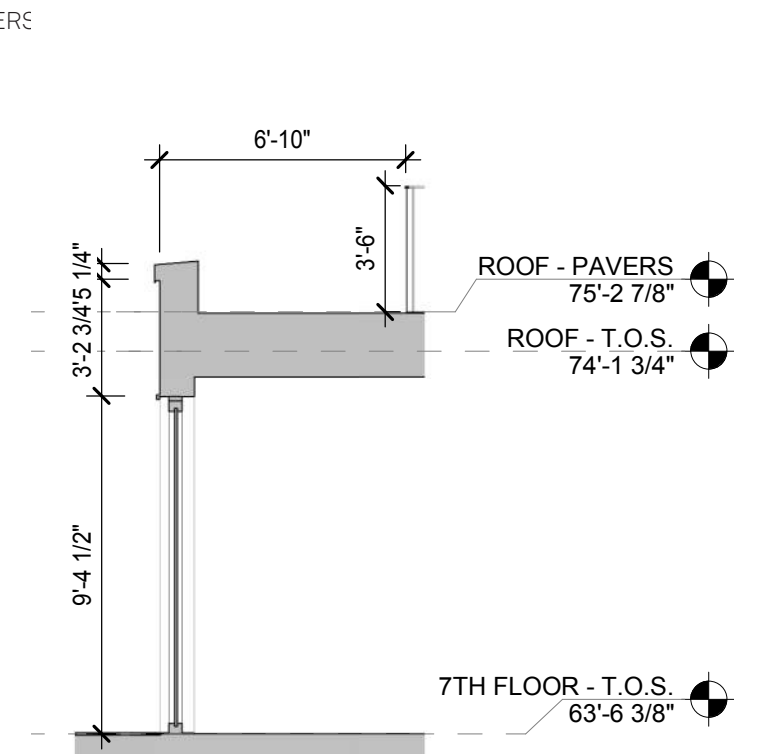

SECTION

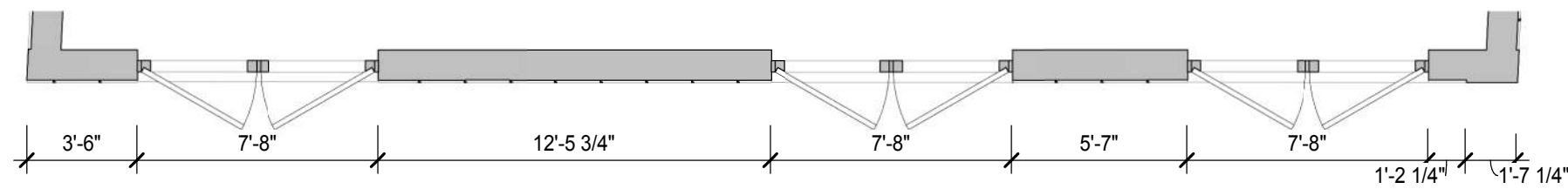

PLAN

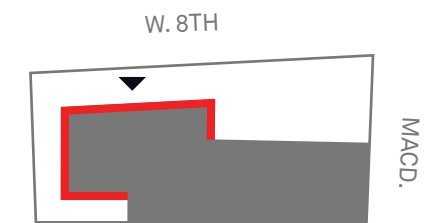

KEY PLAN - PENTHOUSE

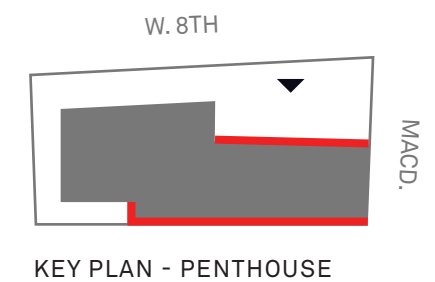
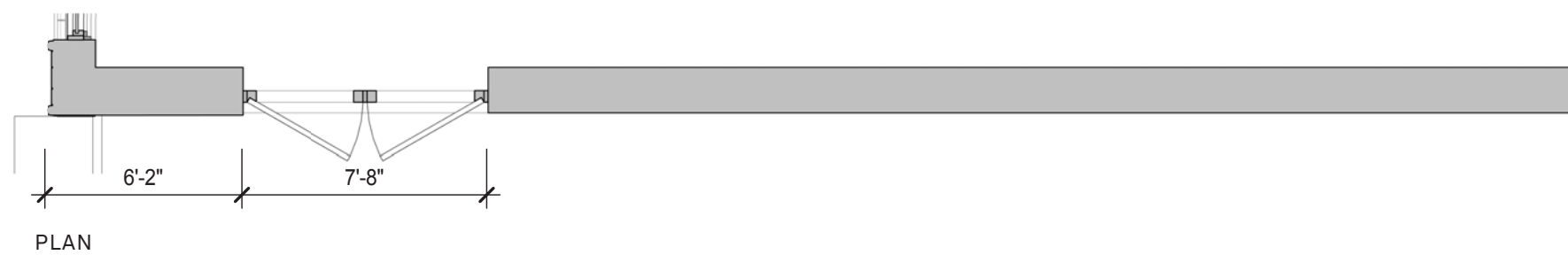
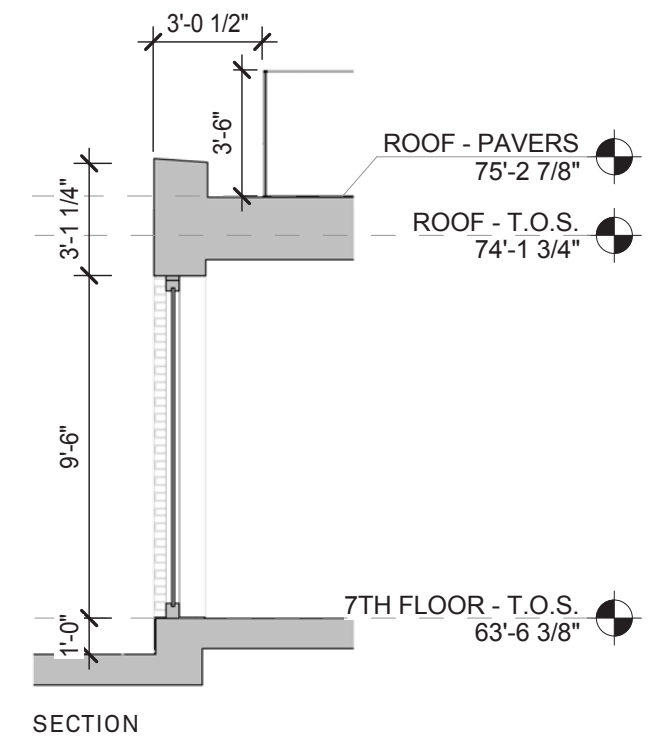
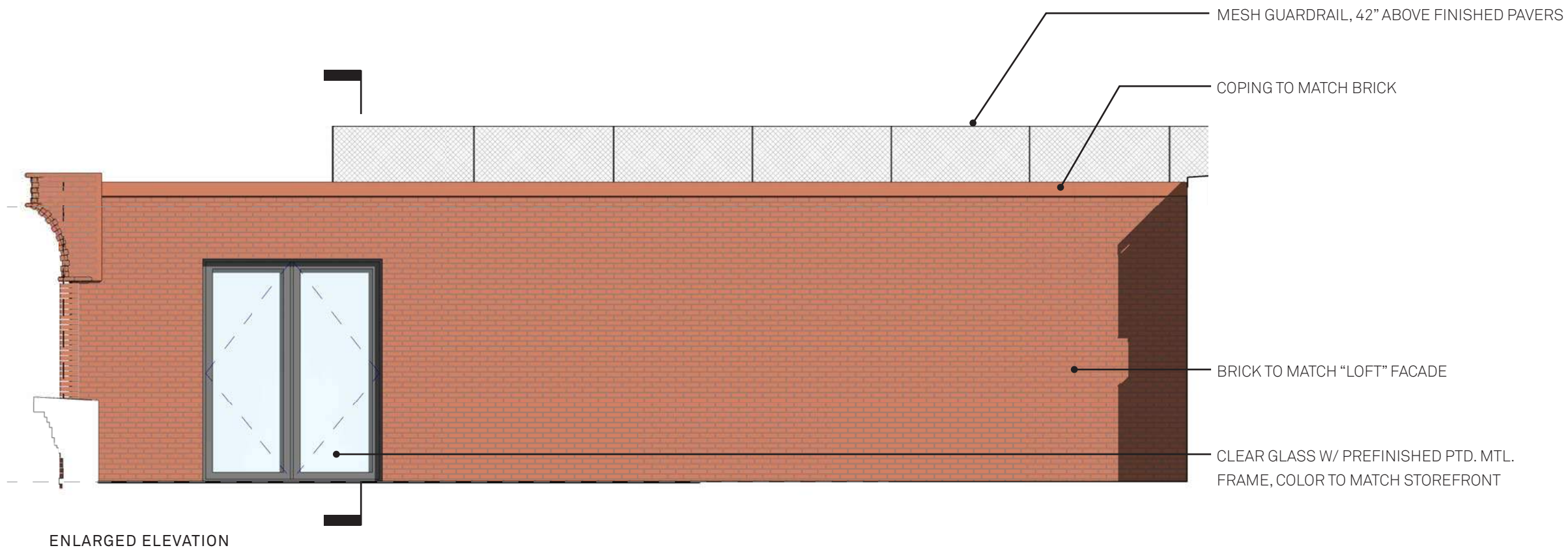

LOFT FACADE



GLEN-GERY BRICK: ILLINI COMMON (STANDARD)

APARTMENT FACADE



SUMMIT BRICK: 711LL THISTLEDOWN SMOOTH

PENTHOUSE METAL



PENTHOUSE BRICK



STANDARD BRICK - BLUSH MIST

WINDOW FRAMES (LOFT)

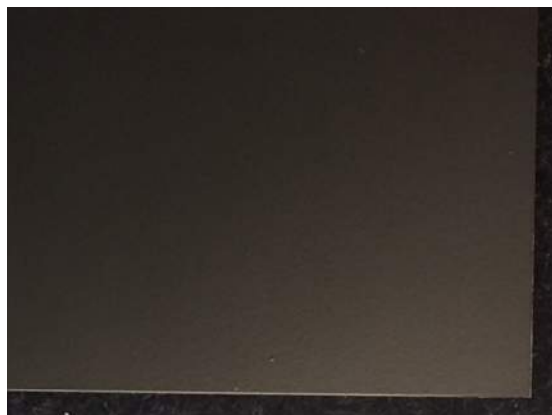

PPG - UC123404 DURANAR BRONZE

WINDOW FRAMES (APARTMENT)

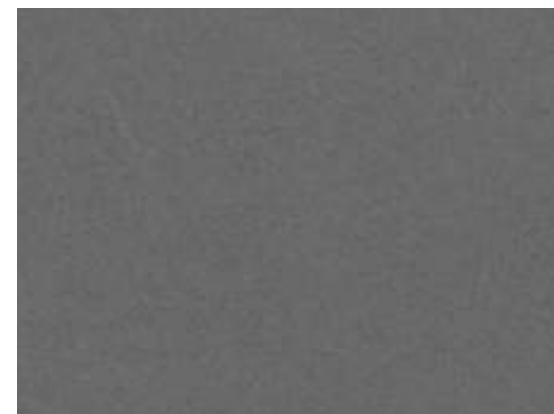

PPG - UC106669 DURANAR ECLIPSE GRAY

PENTHOUSE GUARDRAIL



JAKOB ROPE - WIRE MESH



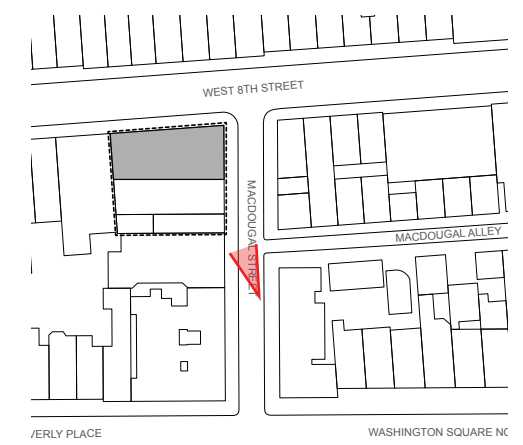



Existing



Proposed





Existing



Proposed





Existing



Proposed





APPENDIX

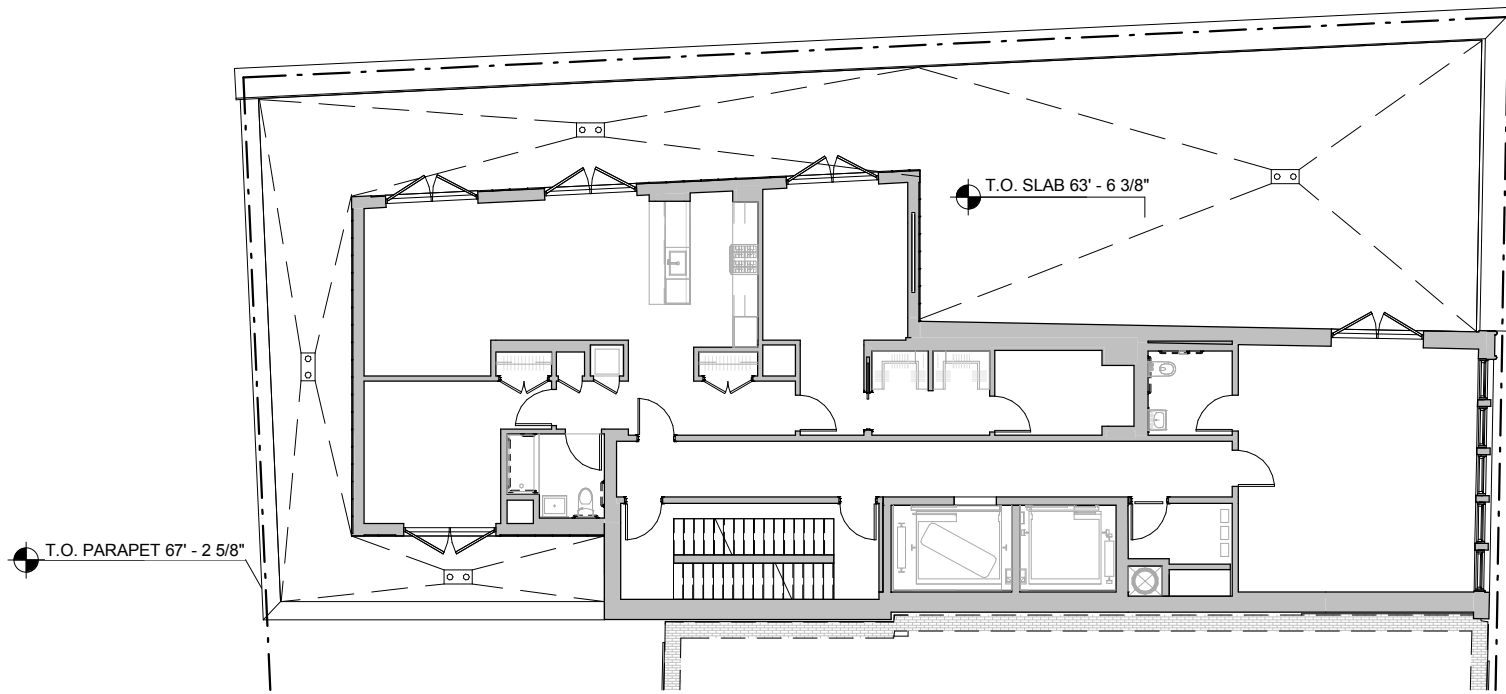

7TH FLOOR PLAN

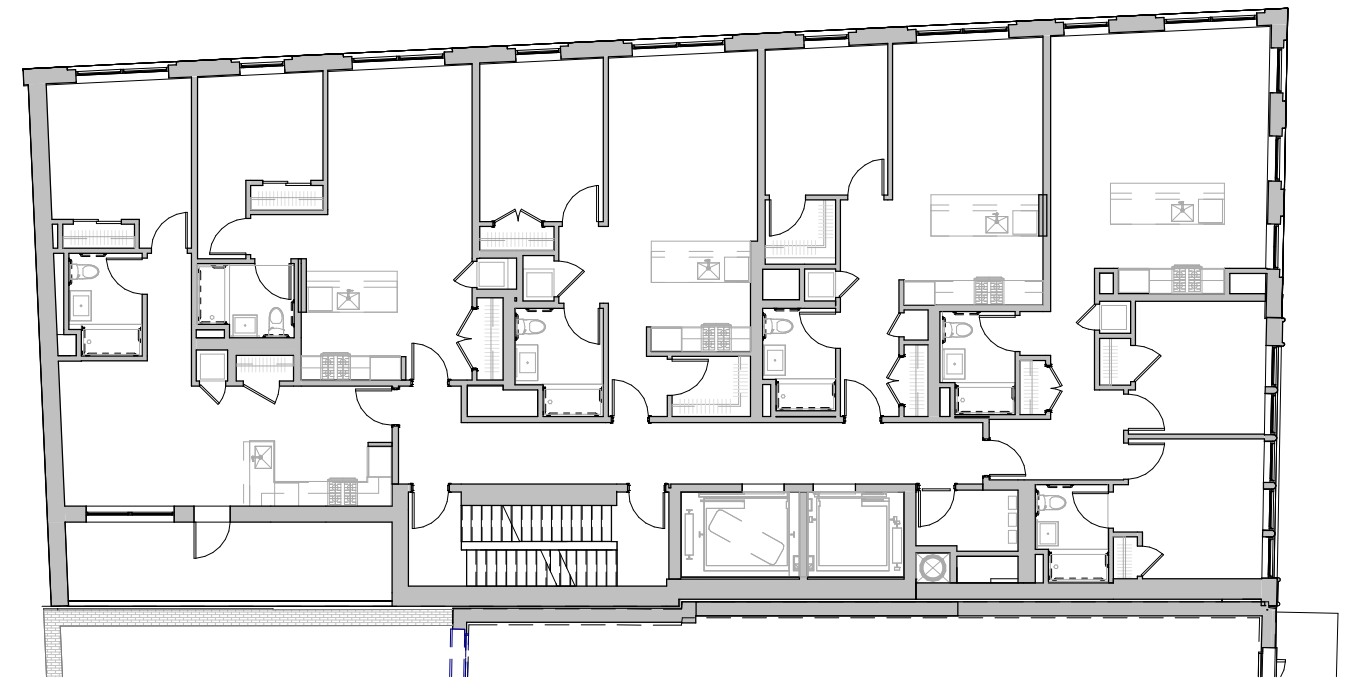

2ND-6TH FLOOR PLAN

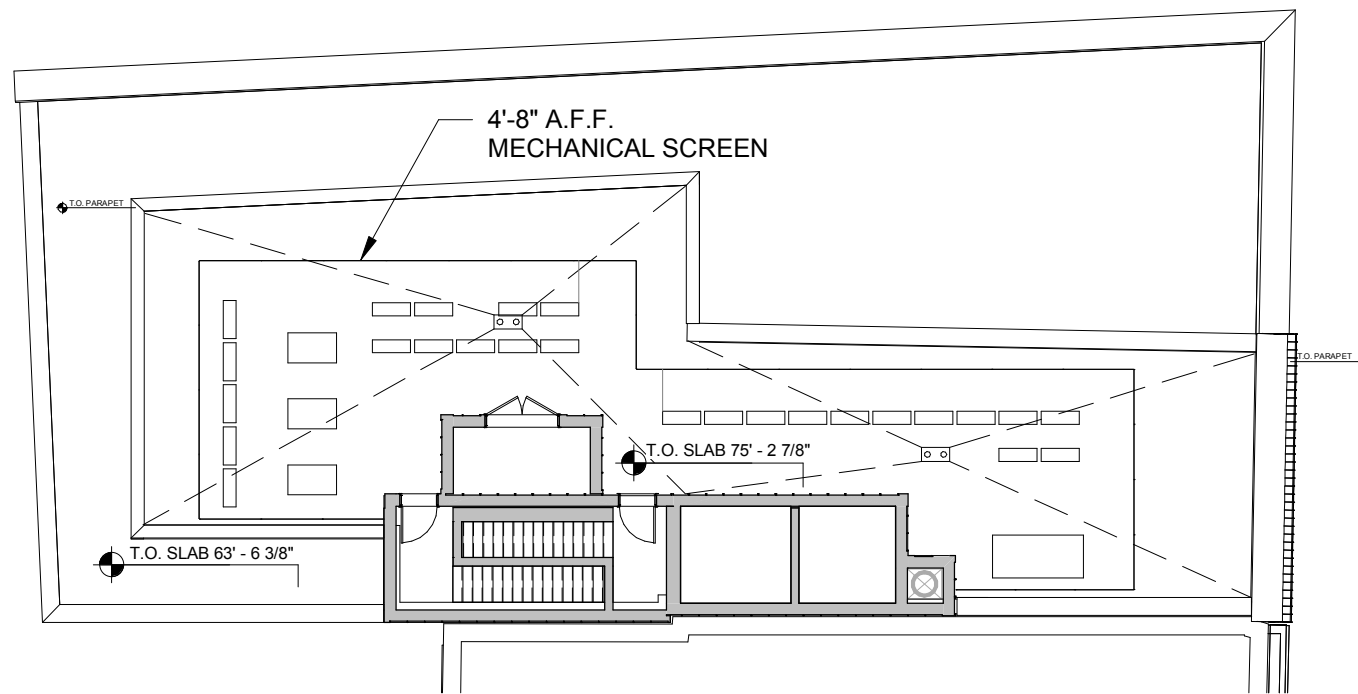

ROOF FLOOR PLAN

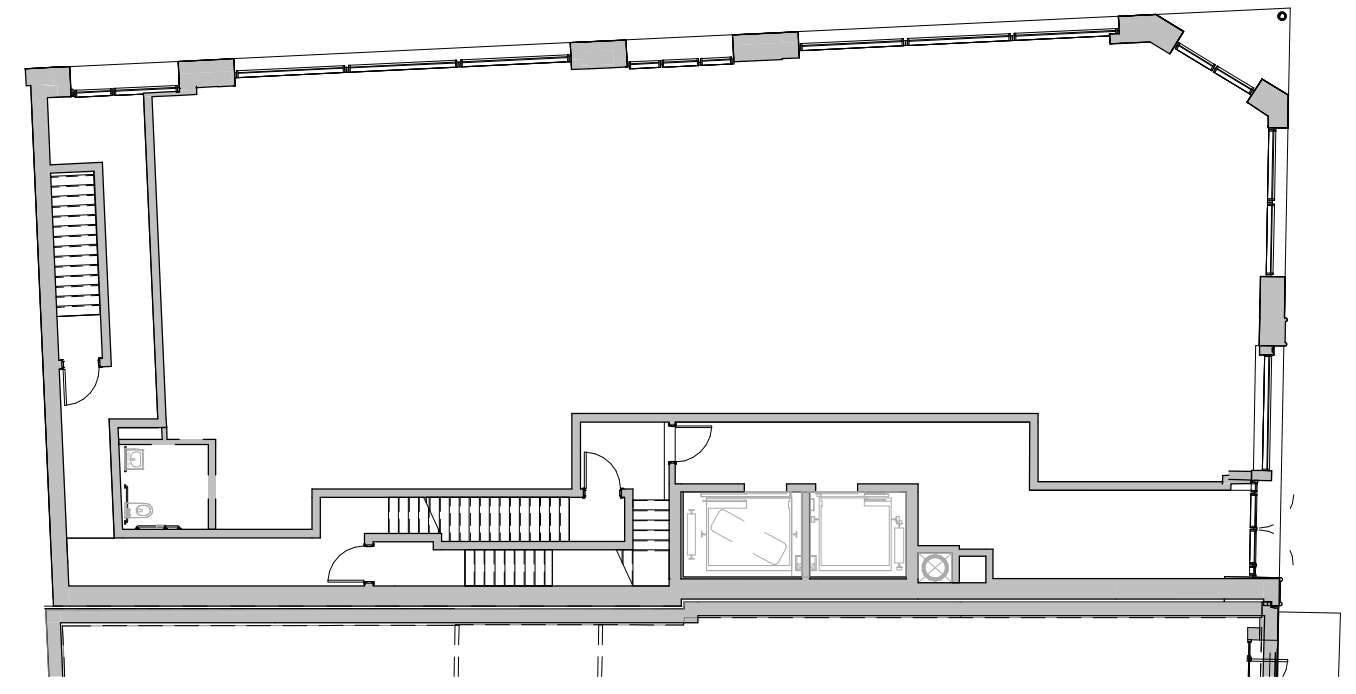

GROUND FLOOR PLAN

